



BPS 140-60

PLASTIC HOUSING / Forward Curved

Fan Components and Material Properties

It has plastic injection body and corrosion resistant plastic fan. The external rotor motor is used to create a compact structure and the device is max. It is capable of carrying air at a temperature of 40°C.

Fan Structure

The forward inclined fan wheel is manufactured from corrosion-resistant plastic and aerodynamically designed to provide regular flow. Thanks to its aerodynamic wing structure, it works quietly. protection grille in fan suction. The fan is made of high quality galvanized steel resistant to corrosion.

Benefits

It works with low noise levels and is designed to be maintenance-free for long periods of time. It can be mounted at desired angle and it has circular section output. In the fan suction, there is a

protection grill in one piece with the body. BPS fans are preferred in applications where acidic or humid air is present. It is lightweight due to its plastic structure. The body has rectangular section output. Speed can be adjusted with speed control devices.

Speed Control

Optional control devices can be provided.

* Speed control can be done with linear voltage regulator. (see BSC accessory)

Usage Areas

BPS fans are preferred in applications where acidic or humid air is present. Due to the plastic structure of the material is light, does not bring large loads where used. Not affected by corrosive air currents.

Technical Drawing and Tables

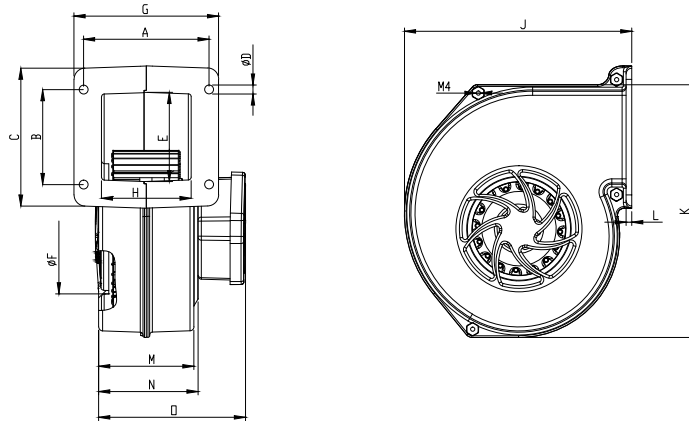

Dimensions are in (mm)

TYPE	A	B	C	D	E	F	G	H	J	K	L	M	N	O
BPS 140-60	110,5	83,5	123	6	76	110	128,5	79,5	201	225	5	85,5	90	130

TYPE	VOLTAGE	FREQUENCY	POWER	CURRENT	CAPACITOR	SPEED	AIR FLOW	SOUND PRESSURE	INSULATION CLASS	PROTECTION CLASS	WEIGHT
	V	Hz	W	(A)	(µF)	r.p.m	m³/h	dB(A)	Ins.cl.	IP	kg
BPS 140-60	230	50/60	150/200	0,66/0,87	4	2500	500	48	B	44	2,4

Sound Level Measured from 3m distance in room condition.

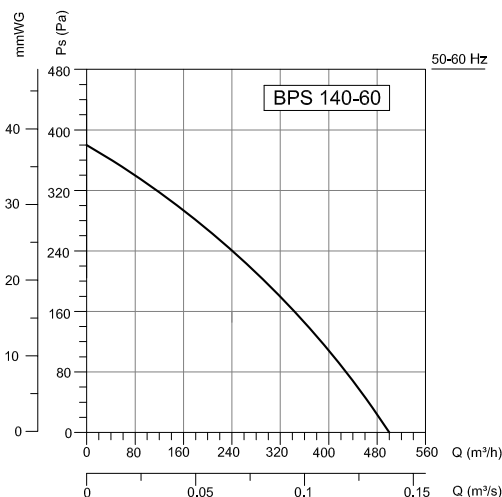

Accessories



BSC