



BSF

DOUBLE INLET RADIAL FANS / Backward Curved

Fan Components and Material Properties

The fan housing is made of high quality galvanized steel which is resistant to corrosion. BRV double suction centrifugal fans are produced as standard in various sizes between 1000 m³ / h and 40,000 m³ / h. The motor and fan impeller are produced on the shaft by means of double bearing and main body with steel carriers.

Fan Structure

Double suction, backward curved high pressure radial type fan. The fan wheel is manufactured from high strength resistant welded steel and streamlined to provide regular flow. Thanks to the suitable aerodynamic wing structure, it works silently.

Benefits

Produces high pressure with backward curved blade structure. It can be adjusted with belt pulley drive system or with inverter. They provide maximum performance with low energy. The fan body can rotate the fan rotor at high speeds.

Speed Control

It can be provided with the optional controller.
 * With belt pulley system or * 3~phase products can be controlled by frequency inverter (see BSC-F accessory)

Usage Areas

Box Fans and air handling units etc. they are preferred.

Technical Drawing and Tables

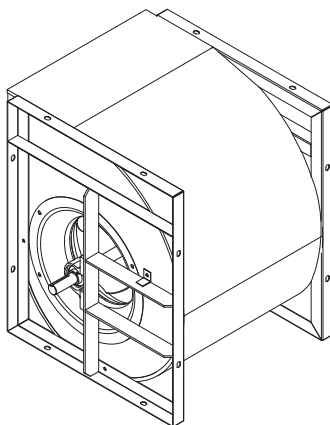
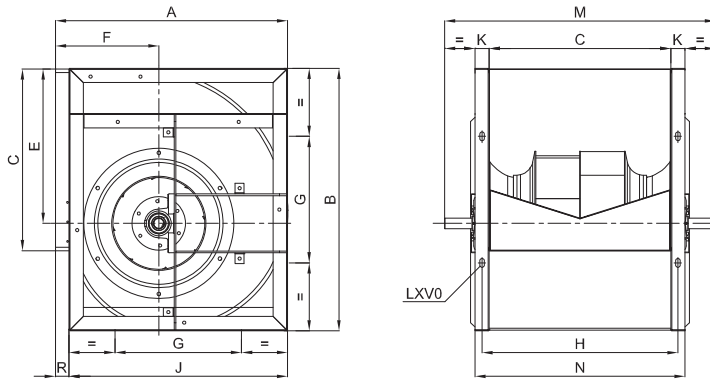
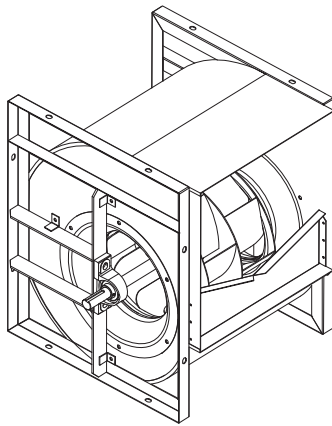

TYPE	AIR FLOW	WEIGHT
	m ³ /h	kg
BSF 280	6000	22
BSF 315	8000	33
BSF 355	10000	45
BSF 400	15000	52
BSF 450	18000	68
BSF 500	26000	85
BSF 560	32000	140
BSF 630	40000	170

Sound Level Measured from 3m distance in room condition.

TYPE	A	B	C	E	F	G	H	J	K	M	N	R	t	t1	W	X	ØD	LXV
BSF 280	466	518	361	302	215	280	391	432	30	540	420	34	8	7	40	28	25	13X18
BSF 315	518	578	404	340	263	330	430	484	30	600	460	34	8	7	40	28	25	13X18
BSF 355	578	655	453	384	261	355	490	548	32	700	520	34	8	7	40	33	30	13X18
BSF 400	651	736	507	432	290	355	549	613	40	760	589	38	8	7	40	33	30	13X18
BSF 450	727	832	569	487	322	530	611	681	40	845	613	46	10	8	50	38	35	13X18
BSF 500	806	920	640	544	352	610	695	754	45	924	736	52	10	8	50	38	35	13X18
BSF 560	894	1031	718	609	390	685	777	842	50	1000	819	52	12	8	70	43	40	13X18
BSF 630	996	1157	801	685	434	766	866	946	50	1092	907	52	12	8	70	43	40	13X18

Dimensions are in (mm)

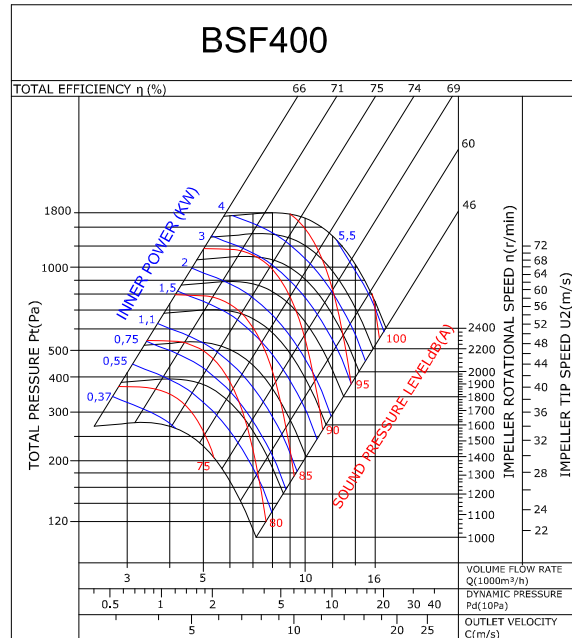
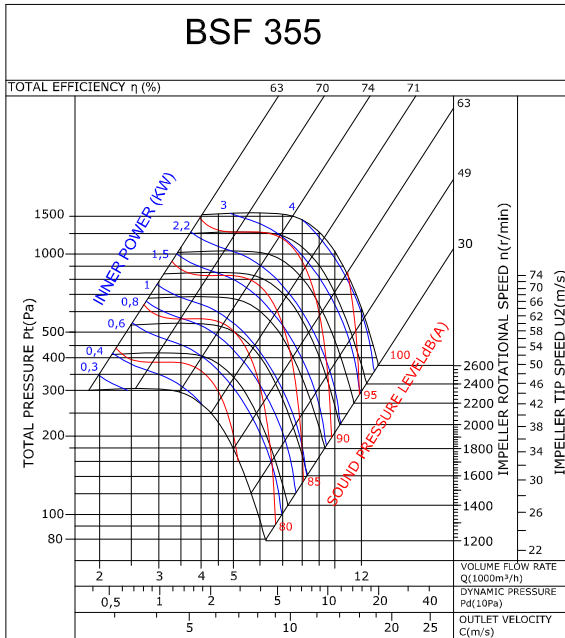
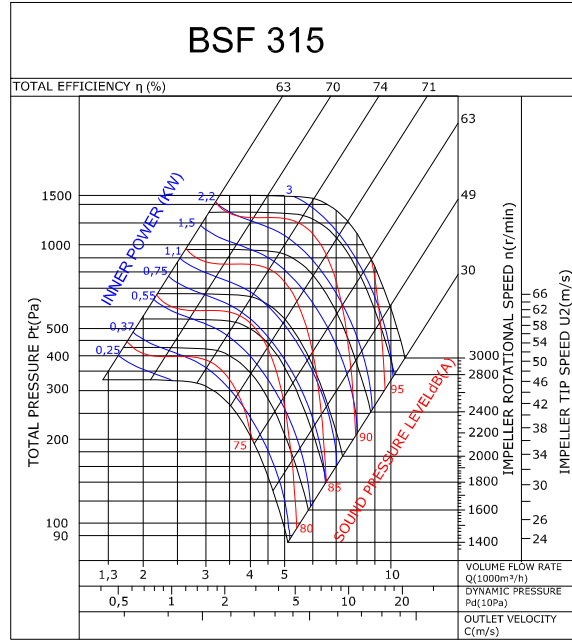
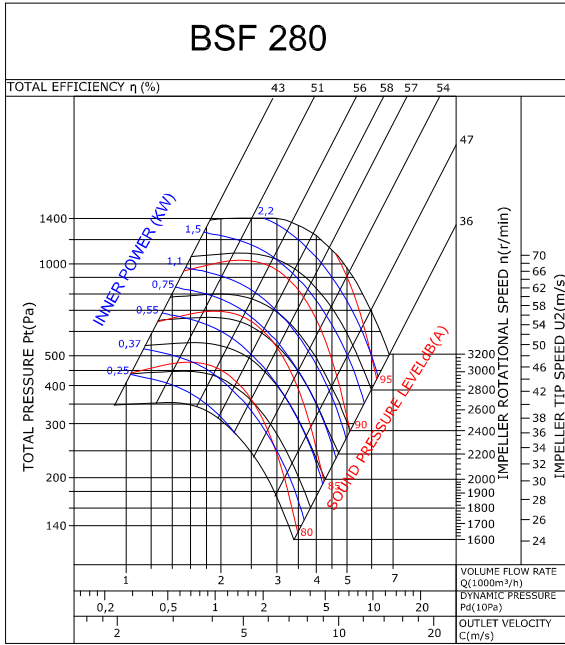

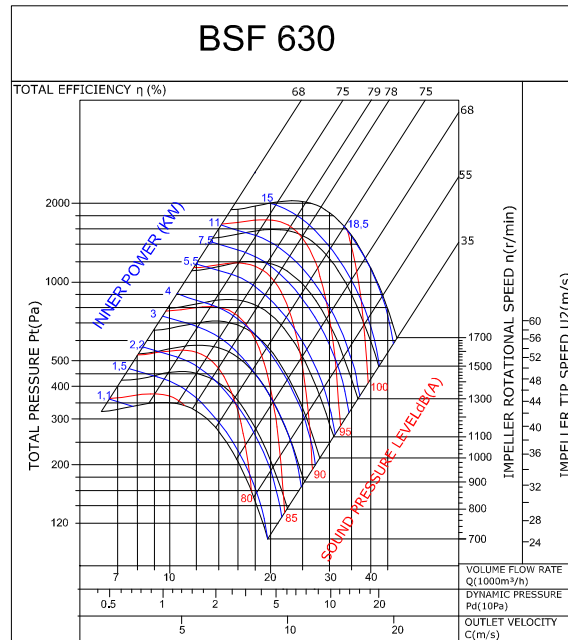
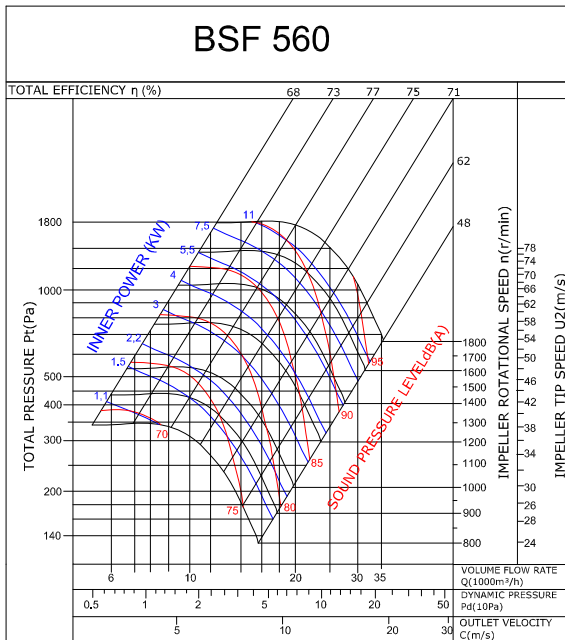
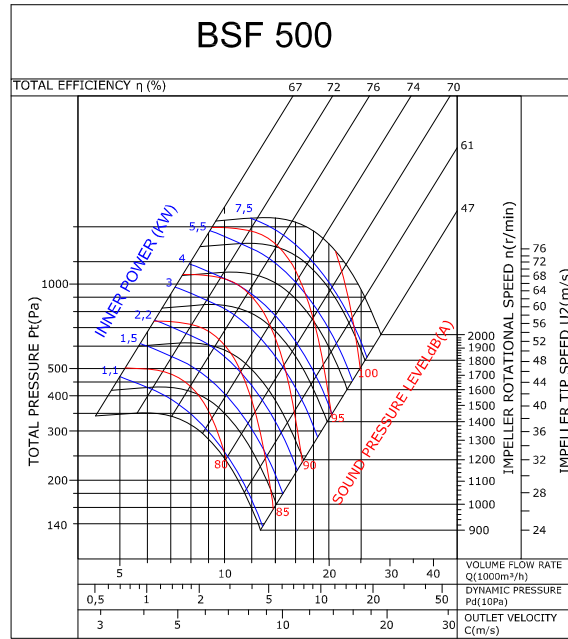
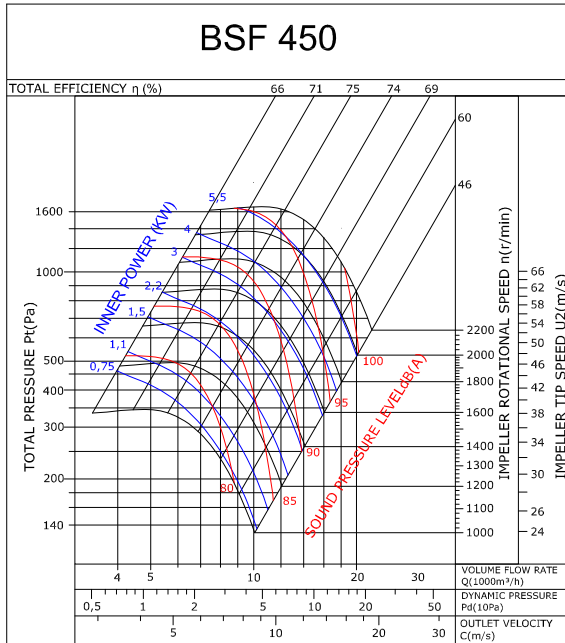

Accessories

